



# FORCE CNC

Now introducing the new **FORCE CNC Rotary Transfer Machine** to the Hydromat platform. This state-of-the-art machine is a ballscrew electromechanical system that offers modularity with options for 1 through 4 axis configurations: providing drilling, tapping, threading, thread milling, single point threading, profiling, and milling capabilities.

- Fully Electromechanical Machine with Ballscrew Drive Technology and Direct Drives
- Standard Machine Equipped Force 50/150 Tool Spindle Units Available in 1, 2, 3, & 4 Axis Configurations
- Machining Capabilities: Drilling, Tapping, Threading, Thread Milling, Single Point Threading, Profiling, and Milling Capabilities
- Utilizes up to 12 or 16 Horizontal Machining Stations and 6 or 8 Vertical Machining Stations
- Maximum Spindle Speed: Mill / Drill Units 8,500 RPM and Lathe Turning 5000 RPM
- Maximum Stock Size that Ranges up to 1.75 Inch Round, 1.5 Inch Hex, 1.25 Inch Square, and a Part Length to 6 Inches
- Designed, Engineered, and Assembled by Hydromat OEM Experts and FANUC Authorized Integrator

#### FORCE 50/150 • SINGLE AXIS

- Standard Unit
- Z Axis

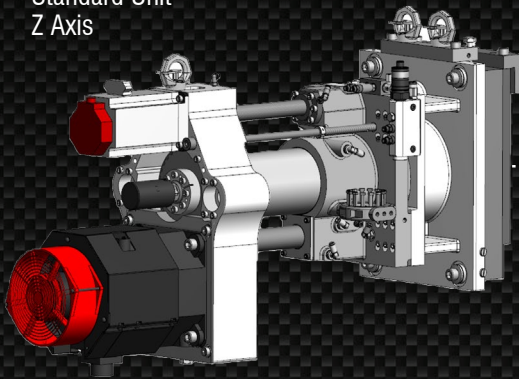

#### FORCE 50/150 • 2 AXIS

- 2 Axis Lathe Unit
- X & Z Axis

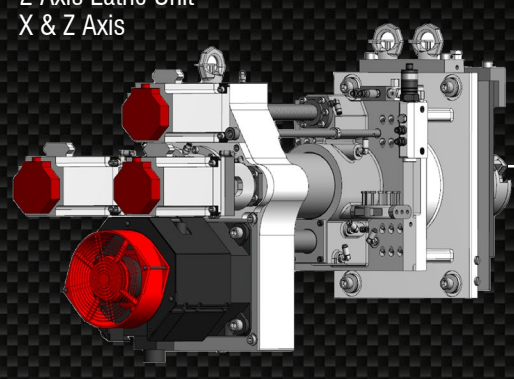

#### FORCE 50/150 • 3 AXIS

- Z - Axis Quill Unit with 2-Axis Cross Slide
- X, Y, & Z Axis

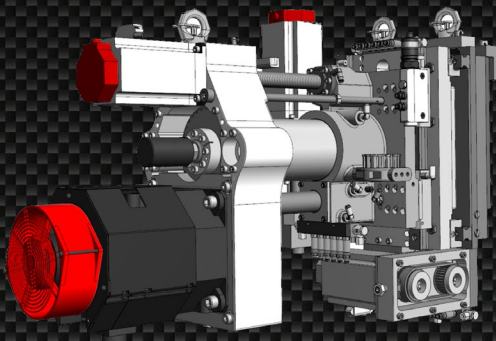

#### FORCE 50/150 • 4 AXIS

- 2-Axis Lathe Unit Integrated with 2-Axis Cross Slide
- X, Y, Z & U Axis

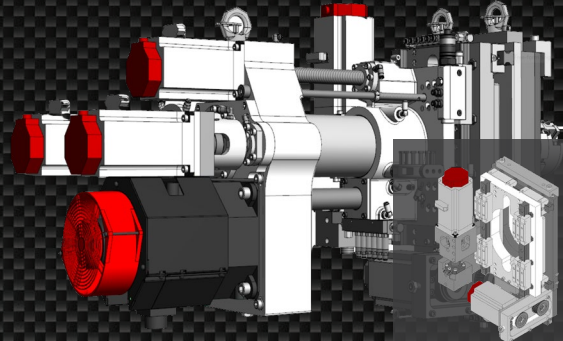

2 - AXIS CROSS SLIDE

PRECISION MACHINING SOLUTIONS

11600 Adie Road • Saint Louis, MO 63043 • 314.432.4644 • [www.hydromat.com](http://www.hydromat.com)





# FORCE CNC

## FORCE CNC 50 / 150 TOOLSPINDLE UNITS

- Fanuc Controlled, Offering Advanced Technology for AI-Learning and Chip Breaking Functions
- Standard with C-Axis Servo Motor for Tapping or Single Point Turning Compatibility
- Direct Coupled Motor/Ballscrew for Y & Z-Axis
- **Unit Configurations:** Single Axis - Z-Axis | 2-Axis - X & Z Axis | 3-Axis - X, Y, & Z | 4-Axis - X, Y, Z, & U
- 4-Axis Lathe Unit Offers Position Control or Eccentric Turning/Boring Requirements
- OEM Designed for Maximized Ergonomics, Physical Size, and Adaptability to the Hydromat Machine

|          |              |              |
|----------|--------------|--------------|
| Z - Axis | 150mm        | Direct Drive |
| Y - Axis | ±30mm        | Direct Drive |
| X - Axis | ±15mm        | Belt Driven  |
| U - Axis | 17mm or 22mm | Direct Drive |

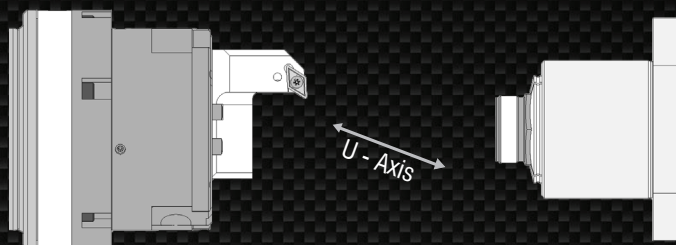
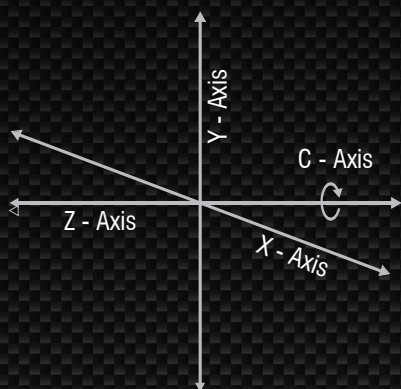

## FANUC 30i MODEL B



The **FORCE** is equipped with a **FANUC 30i Model B Control**, an intuitive and easy-to-use interface that caters to both programmers and on-site operators. This advanced control system offers a 15-inch color display and a variety of programming options, including conversational and G-code programming. The control also features a high-speed processing capability, allowing for faster cycle times and improved productivity. Additionally, the control system has advanced diagnostic and maintenance features, enabling easy troubleshooting and maintenance.

At Hydromat, we take pride in being a part of the **FANUC America Authorized CNC System Integrator (ACSI) Network**. As an ACSI, we receive exclusive training and product updates, keeping us well-versed in the latest features and technologies. Our team collaborates closely with FANUC to ensure that we possess the necessary technical expertise and product knowledge to provide the best solutions that meet our customers' needs and exceed their expectations.